

# Automatic Round Damper (ARD)

**PRODUCT DATA**



## FEATURES

- Adjustable damper position range stops.
- Single-blade damper.
- Shipped as power closed/spring return open damper.
- Galvanized steel.
- Can be field-converted to power open/spring return closed damper.
- Blade closes off tightly against gasket for minimal leakage.
- Rated to operate up to 1 in. wc. (see specifications).
- Male (crimped) and female (uncrimped) ends to connect to any rigid or flexible round duct.

## APPLICATION

The ARD is a round damper with a 24 Vac, spring-return damper motor used to control circulating air in heating, cooling, and ventilating systems.

The damper is shipped as a powered closed/spring return open damper for use with the TotalZone® Damper System, Electronic MiniZone™ Damper System and other normally-open damper systems.

The damper can be field-converted to a power open/spring return closed damper when used as an independent zone or for fresh air intake for ventilation or combustion make-up air.

## Contents

Application .....	1
Features .....	1
Specifications .....	2
Ordering Information .....	2
Installation .....	3
Wiring .....	3
Checkout .....	4



## SPECIFICATIONS

### IMPORTANT

The specifications given in this publication do not include normal manufacturing tolerances. Therefore, this unit may not exactly match the listed specifications. Also, this product is tested and calibrated under closely controlled conditions, and some minor differences in performance can be expected if those conditions are changed.

### Construction:

Frame: Galvanized steel spiral duct, crimped on downstream side.

Sizes: 5 in., 6 in., 7 in., 8 in., 9 in., 10 in., 12 in., 14 in., 16 in., 18 in., and 20 in. diameters.

Gauges: ARD5-ARD12: 24 Gauge frame, and 22 Gauge blade

ARD14-ARD20: 22 Gauge frame, and 20 Gauge blade.

**Motor Electrical Rating:** 24 Vac, 60 Hz, 6VA.

**Motor Electrical Connection:** 4 in. leadwire.

**Motor Nominal Angular Rotation:** 90°.

**Motor Torque:** Minimum 60 in.-oz. (423 milli-newton meters) output torque available when motor is energized and device is at the spring return initial start position.

### Nominal Motor Timing at 77°F (25°C) Ambient:

Energized at rated load: 30 seconds.

De-energized (spring return): 10 seconds.

**Motor Ambient Temperature Rating:** 40° to 140°F (5° to 60°C).

**Leakage:** Less than 1% at 1/2 in. wc.

**Pressure Drop:** Maximum at full open: 0.0329 in. wc at 800 ft/min.

**Maximum Static Pressure:** 1 in. wc for all models except 0.3 in. wc for ARD20.

**Motor Shaft Rotation Direction:** Clockwise, when energized and viewed from the base or shaft end.

**Motor Mounting Means:** Direct connection to damper shaft.

**Motor Mounting Position:** Multi-prise.

**Motor Dimensions:** See Fig. 1.

\* Nominal Device Dimensions (see Fig. 1.).

	A	B	C	D	E	F
in.	3-1/2	3	2-3/8	1-1/2	*	**
mm	89	76	60	38	*	**

\* Diameter is derived from the part number, i.e. ARD10 has a 10 in. diameter.

\*\* Length is equal to the diameter plus 2 in. (51 mm)

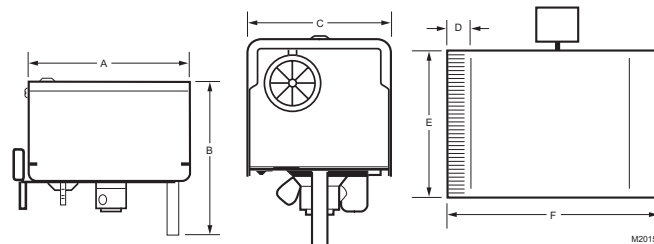

Fig. 1. Motor dimensions in in. (mm).

## ORDERING INFORMATION

When purchasing replacement and modernization products from your TRADELINE® wholesaler or distributor, refer to the TRADELINE® Catalog or price sheets for complete ordering number.

If you have additional questions, need further information, or would like to comment on our products or services, please write or phone:

1. Your local Honeywell Automation and Control Products Sales Office (check white pages of your phone directory).
2. Honeywell Customer Care  
1885 Douglas Drive North  
Minneapolis, Minnesota 55422-4386

In Canada—Honeywell Limited/Honeywell Limitée, 35 Dynamic Drive, Scarborough, Ontario M1V 4Z9.

International Sales and Service Offices in all principal cities of the world. Manufacturing in Australia, Canada, Finland, France, Germany, Japan, Mexico, Netherlands, Spain, Taiwan, United Kingdom, U.S.A.

## INSTALLATION

### Before Installing this Product...

1. Read all instructions before installing this product. Failure to follow the instructions can damage the product or cause a hazardous condition.
2. Check the ratings given in the instructions and on the product to make sure the product is suitable for your application.
3. Installer must be a trained, experienced service technician.
4. Install the product in an area that is easily accessible for checkout and service.
5. After completing installation, use these instructions to check out the product operation.

### Installing the Round Damper

1. Insert the crimped end of the ARD into the uncrimped end of the rigid round duct and secure with rigid sheet metal screws (not provided). When using flexible duct, slip the duct over the end of the ARD and secure it with duct straps (not provided).
2. When installing the damper in a horizontal application, make sure the motor actuator is located on the side or top of the damper. Do not locate the motor on the bottom of the damper. The damper can be mounted in a vertical duct.
3. Check and verify that the air flow indicator is pointing in the direction of the air flow duct.

## WIRING



### CAUTION

**Personal Electrical Shock Hazard.**  
**Can cause electrical shock or equipment damage.**  
 Disconnect power before beginning installation.

The damper motor has a 24 Vac, 50/60 cycle, 6 VA rating. The spring-return ARD damper requires 24 Vac to the two motor leads to power the damper. The damper then returns to its normal position. See Fig. 3 and 4 wiring diagrams.

NOTE: Multiple ARD can be wired in parallel.

### Wiring a Motor

See Fig. 3 and 4 for motor wiring hookups.

### Changing a Motor

1. Disconnect the motor wiring.
2. Loosen the large socket head cap set screw located between the faceplate and the motor coupling.
3. Remove the motor.
4. Ensure damper blade is in the open position with the set screw pointing toward the open position on the label.
5. Attach new motor to the coupling; be sure the standoff on motor is positioned in the grommet on the faceplate and the set screw is aligned with the motor shaft hole.
6. Tighten the set screw.

### Adjusting a Motor

1. When viewed on end, the lower lever is normally positioned to the extreme left and the upper lever is to the extreme right. See Fig. 2. This position provides complete shutoff when the damper is closed.
2. To prevent complete closure of the damper, loosen (do not remove) the wing nut on the bottom of the motor and move the upper lever to the left until the desired position is reached. Tighten the wing nut. In the extreme left position, the damper should stay open approximately 40° when powered shut.
3. The lower lever is normally positioned to the left to allow the damper to fully open 90° when de-energized. See Fig. 2.
4. To restrict the air flow in the open position, loosen (do not remove) the wing nut and move the level to the right until the desired position is reached. Tighten the wing nut. In the extreme right position, the damper should open approximately 50° with the power off.

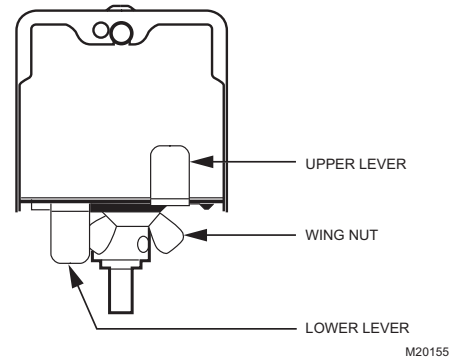

Fig. 2. Air flow adjustment.

### Wiring a Single ARD (Power Open) to a Thermostat

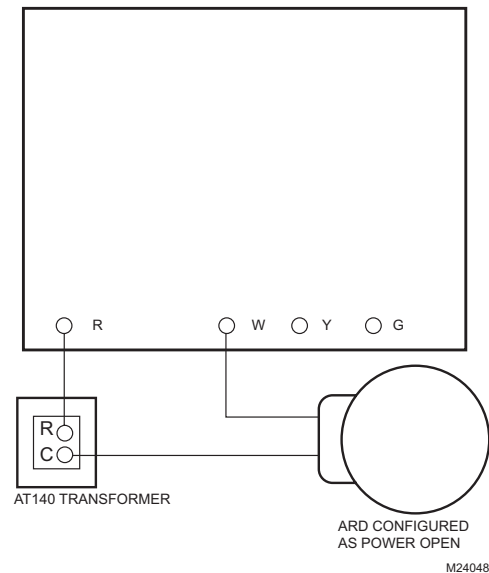

Fig. 3. ARD configured as power open.

## Wiring a Single ARD (Power Closed) to a Control Panel

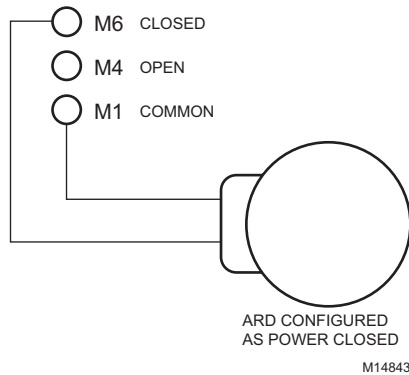

Fig. 4. ARD configured as power closed.

## Changing ARD Power Closed to Power Open

1. Remove power to motor (damper blade in open position).
2. Loosen socket head cap set screw and remove motor.
3. Pinch and push grommet (with hole) to remove.
4. Push out plastic plug.
5. Exchange the positions of the grommet and the plug.
6. Manually place damper blade in closed position.
7. Place motor on opposite side of damper. (This side should now have the grommet with the hole.)
8. Tighten the cap screw. (Make sure the blade is in the closed position.)
9. If using a zoning panel, change the power wires from M1 and M6 to M1 and M4.

## Changing ARD Power Open to Power Closed (Factory Default)

1. Disconnect the motor wiring (damper blade in closed position).
2. Loosen socket head cap set screw and remove motor.

3. Pinch and push grommet (with hole) to remove.
4. Exchange the positions of the grommet and the plug.
5. Manually place damper blade to open position.
6. Place motor on opposite side of damper. (This side should now have the grommet with the hole.)
7. Tighten the cap screw. (Make sure the blade is in the open position.)
8. If using a zoning panel, change the power wires from M1 and M4 to M1 and M6.

## CHECKOUT



### CAUTION

#### Possible Equipment Damage

Do not manually open or close the damper as this can damage the actuator.

To check out the ARD:

1. With 24 Vac applied to the motor leads, observe the motor powering the damper to the closed position.
2. When energized, verify that the actuator connection coupling rotates in a clockwise direction (as viewed from the operator base end) and that the damper shaft turns with the coupling.
3. With power removed, observe the damper returning to the normally-open position.

NOTE: To remove power, disconnect one wire from the motor.

4. If the motor does not operate smoothly and without hesitation throughout the complete opening and closing stroke, examine the damper and the shaft for free rotation within the duct.
5. If the full opening and closing is not achieved, check that the lower adjustment lever is to the extreme left and the upper lever is to the extreme right. See Fig. 2.

### Automation and Control Solutions

Honeywell International Inc.  
1985 Douglas Drive North  
Golden Valley, MN 55422  
customer.honeywell.com

Honeywell Limited-Honeywell Limitée  
35 Dynamic Drive  
Scarborough, Ontario M1V 4Z9

