

PC3F4344IUF00 Hydronic Circulating 3 Speed Pump

SPECIFICATION DATA

APPLICATION

The PC3F in-line, wet rotor circulator with universal flange is designed for applications in closed-loop hydronic heating and cooling systems, as well as in solar-powered systems. The pump is non-submersible and for use in dry, frost-free, well-ventilated installations.



SPECIFICATIONS

Rate of flow: up to 59 gpm (223 lpm)

Pressure head: up to 17 ft (5.2 m)

Voltage:
115VAC +/-10% 60hz

Amperage: See "Speed switching" on page 2.

Max. Pressure:
145 psi (at room temperature);
50 psi (at 200°F [93°C])

Temperature Range:
Ambient temperature: 32°F to 104°F (0°C to 40°C)
Media temperature: 14°F to 230°F (-10°C to 110°C) [to 200°F (93°C) with optional check valve installed]

Storage Temperature: -40°F to 100°F (-40° to 38°C)

Standards:
Insulation Class F
Temperature Class FT 95

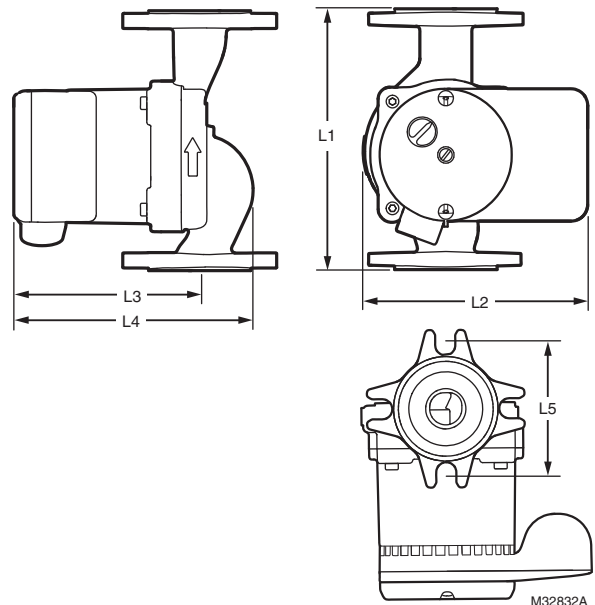

Fig. 1. Pump dimensions in in. (mm).

L1	L2	L3	L4	L5
8.5 (216)	6.1 (155)	6.9 (174)	8.9 (227)	3.4 (87.3)

Shipping weight: 11 lbs (5 Kg)



Materials

Component	Material
Pump body	Cast iron
Impeller	Polyamide
Shaft	Ceramic
Bearing	Ceramic
Bearing plate	Stainless steel
Can	Stainless steel

Control: 3-step switch with manual speed selection

Motor protection

The motor includes an internal thermal overload protection. External motor protection is not required.

Speed switching

Three speed, with manual selector.

Speed	Volts	Amps	Watts
1	115	1.26	145
2		1.61	185
3		1.83	210

Flange Connections

Universal flange
 Bolt hole spacing 3-7/16 in. (87.3 mm)
 Bolt holes 1/2 in. (12.7 mm)

Media

Clean water or water with up to 20% glycol. Up to 50% glycol may be used, but flow characteristics will differ from these specifications.

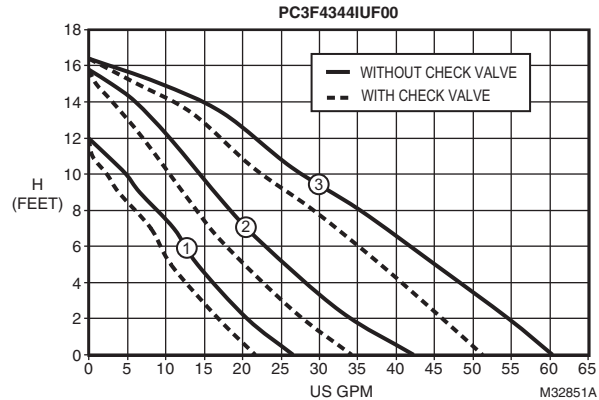

Fig. 2. Flow curve characteristics.

Optional and Replacement Parts

Check valves: PCV150
 Flange gasket: PCG150

Table 1. Cross Reference for Pump Replacement

Honeywell			Grundfos		Taco		Bell & Gossett	Armstrong
Model	Pump Length	Speed	Single Speed	3-Speed	Single Speed	3-Speed		
PC3F4344IUF00	8.5"	High	UP43-44F UP43-44F-FC	UPS43-44 High UPS43-44-FC High			HV H-32	E16
		Medium		UPS43-44 Med UPS43-44-FC Med	0010F 0012F-IFC	0010 Med	NRF-33	H32
		Low		UPS43-44 Low UPS43-44-FC Low	0010F-IFC	0010 Low		

The information in this table is based on publicly available information as of the date of this publication. Honeywell is not liable if information is found to be incorrect.

If the cross-referenced model uses a flow check valve, then use a flow check with the Honeywell model as well.

Each Honeywell circulator replaces both regular and rotated flange models.

Automation and Control Solutions

Honeywell International Inc.
 1985 Douglas Drive North
 Golden Valley, MN 55422
 customer.honeywell.com

